

**DRAWING NOTES**

- All dimensions in mm U.O.S.
- All measurements ±1mm.
- DO NOT SCALE DRAWING.

**SPECIFICATION INFORMATION**

- Opening in back wall cast to suit outer dimension of pipe.
- Invert level of pipe can be set to your specification.

**HEADWALL INSTALLATION**

Units should be bedded on minimum 150mm thick well compacted Class 6N or 6K\* well graded granular material with 50mm topping of fine material (Class 6L\*) to ensure units are level and stable. \*Manual of contract documents for Highway Works: Volume (MCHW1) specification for Highway Works, Series 600 (Nov 09).

**HANDLING**

A. Weight of concrete is based on 2.4 tonne/m<sup>3</sup> +5% is recommended for sizing lifting equipment.

B. All lifting points shall be used as specified below

C. Unit to be lifted as per lifting diagram.

**CONCRETE**

A. Mix ref: Self-compacting DC4 / DS4 Mix.

B. Lifting strength based on 2 cubes = 20N/mm<sup>2</sup>.

C. Characteristic 28 day cube strength = 50N/mm<sup>2</sup>.

D. Concrete provides Design Chemical Class 4 (DC4) to special Digest 1, Table F2.

**REINFORCEMENT**

A. Reinforcement to BS EN 13369.

B. Scheduling, dimensions, bends & cutting to BSS866.

C. Cage to be machine tied with steel wire.

**MANUFACTURE**

A. Manufacture to BS EN 15258:2008 precast concrete products retaining wall elements, factory production control certificate 0086-CPR-650448 & BS EN 13369.

B. Tolerances to BS EN 13369 clause 4.3.1.1.

C. Finishing:

Class	Top	Sides	Rear	Rear of Backwall
	A	A	A	Self-Levelled

D. Marking. Units shall be indelibly marked to show:

- Mould reference code.
- De-mould date.
- Job reference number & unique product number.
- Unit weight (kg).

**DESIGN**

A. Concrete structure designed to Eurocode 2.

B. JKH have designed concrete units only, the site conditions should be assessed for suitability by the scheme designer

C. Units are designed to withstand a vertical live load surcharge of 10kN/M<sup>2</sup>.

D. Weight of soil = 18kN/M<sup>2</sup>.

E. Angle of internal friction = 30 Deg.

F. Design Life as table below \* (all cover sizes in mm).

Design Life	>50 years, 100mm Wall Thickness				>100 years, 150mm Wall Thickness				
	Block Size Cover	Min Size Cover	Max Size Cover	Block Size Cover	Min Size Cover	Max Size Cover	Block Size Cover	Min Size Cover	Max Size Cover
Minimum Cover for All Faces	33	28	38	55	50	63			

\*Design life of >100 years can be extended to >120 years with Bitumen coating application.

Exposure Classification	Exposure induced by Carbonation		Corrosion induced by Chloride		Freeze/thaw attack		Chemical attack	
	Min Size Cover	Max Size Cover	Min Size Cover	Max Size Cover	Min Size Cover	Max Size Cover	Min Size Cover	Max Size Cover
All Faces	33	28	33	28	33	28	33	28

**FABRICATION SPECIFICATION**

A. Manufacture IAW EN 1090-2 EXC CLASS 1

B. Material grade is to be: BS EN 10025 S275

C. Welding to IAW EN 1090-2 PARA 7.5.4 - 7.5.18

D. All fillet & butt welds to have minimum throat thickness of 6mm and joints fully welded where possible.

E. Ensure vertical flats fully welded both sides where possible

F. All sharp edges and burrs are to be removed.

G. Remove all weld splatter.

H. Hoies by punching are permitted with reaming.

I. Galvanising process after fabrication to BS EN ISO1461.

**HANDRAIL SPECIFICATION**

A. Kee Klamp® Galvanised Size 8 Fittings.

B. Size 8 48.3mm OD 3.2mm Wall Thickness Galvanised Medium Duty Tube to BS EN 10255

C. 360N/m Design Load as stated in BS 8118, BS 6180, BS 6399 & BS 7818, Civil Engineering Specification for the Water Industry (CESWI) 7th Edition Clause 2.60 Handrails & Balusters & The Engineering Equipment and Materials Users' Association (EEMUA) Publication 105 7th Edition Factory Stairways, Ladders and Handrails.

D. Other design loads available on request.

E. GRP/FRP Handrails also available.

ADDRESS: JKH LIMITED  
CHISWICK AVENUE  
MILDENHALL  
IP28 7AY

WEBSITE: [www.jkhlimited.co.uk](http://www.jkhlimited.co.uk)  
EMAIL: [sales@jkhlimited.co.uk](mailto:sales@jkhlimited.co.uk)  
TEL: 01638 713795

PROPRIETARY & CONFIDENTIAL. Information contained on this drawing is the sole property of JKH Drainage Units Ltd. Any reproduction in part or as a whole without the written permission of JKH Drainage Units Ltd is strictly prohibited.

**DRAWING TITLE:**

**SERIES 2000 HEADWALL (2130 HIGH)  
LEVEL WINGWALL  
STANDARD & OPTIONAL FEATURES**

**TOTAL WEIGHT (CASTINGS ONLY):** 4270 kg

**CONCRETE MIX DESIGN:**

**CO<sup>2</sup> EMISSION  
REDUCTION ↓ -50%**

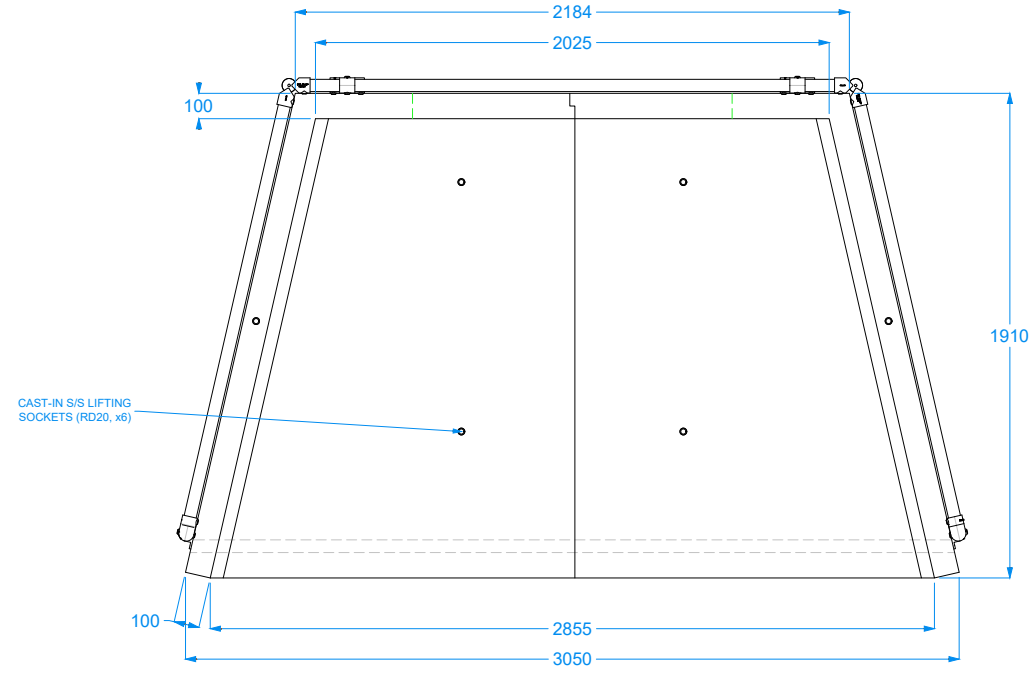

VIEW: TOP

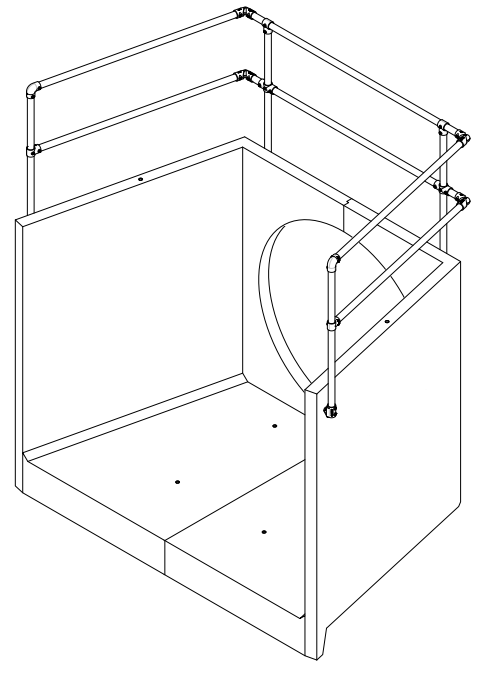

VIEW: ISOMETRIC

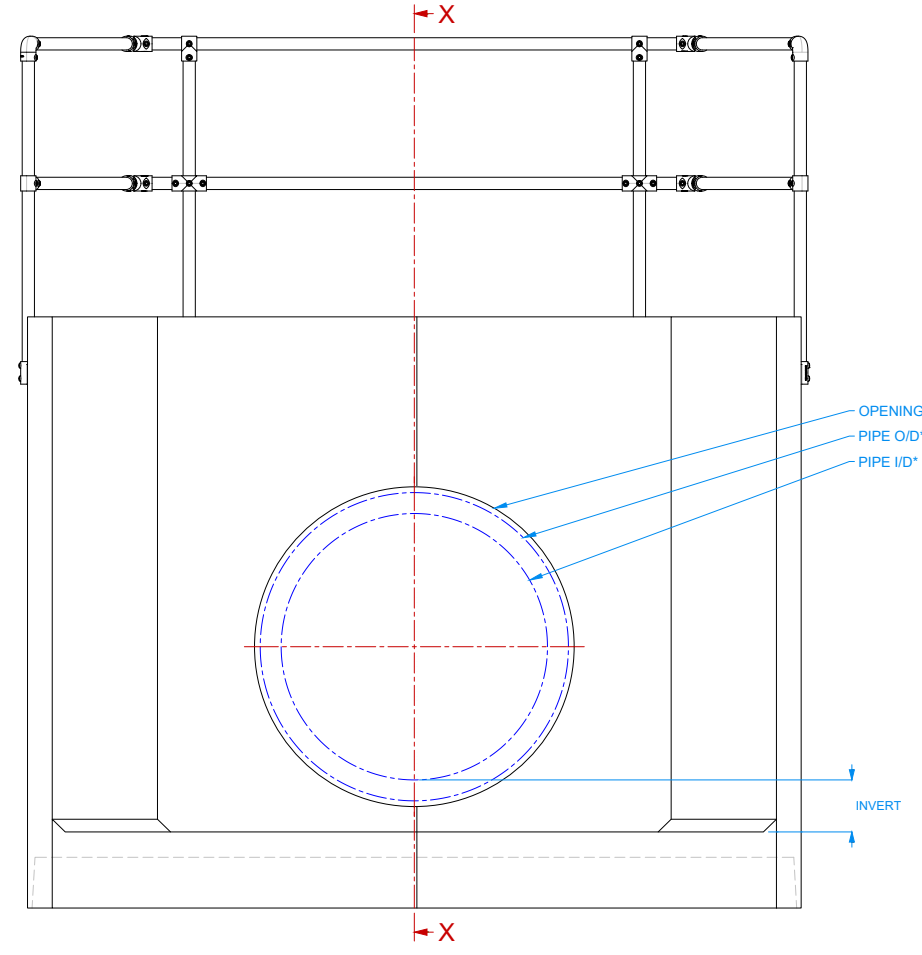

VIEW: FRONT

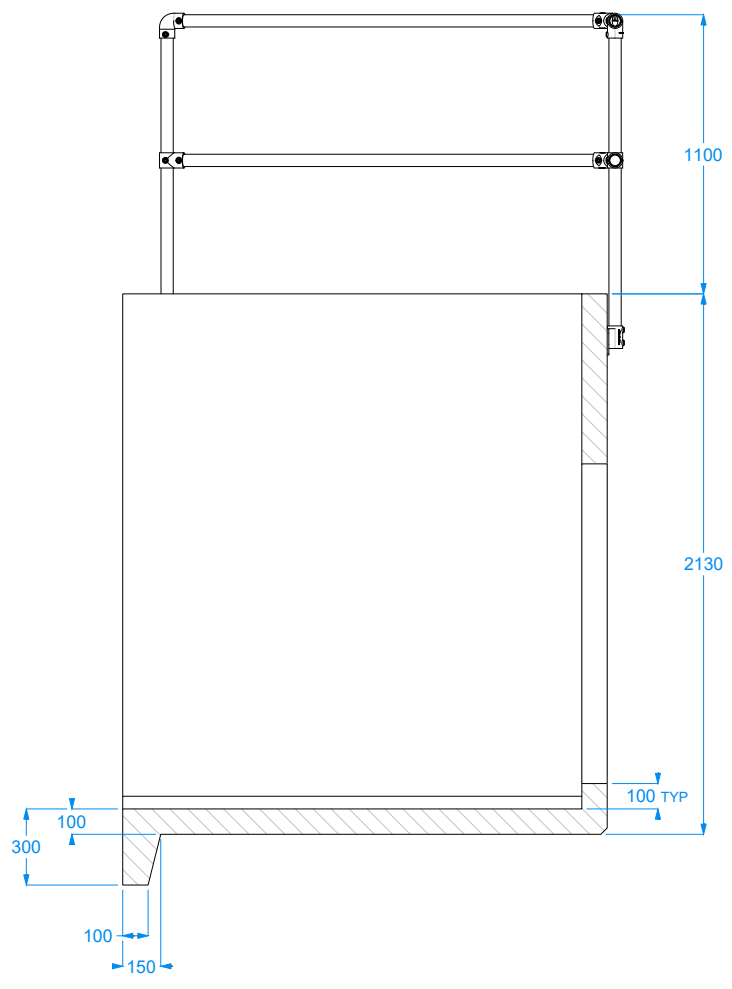

VIEW: SECTION

**STANDARD FEATURES**

**OPENING SIZE GUIDE**

Ø1850 mm  
MAXIMUM  
OPENING

TYPICAL MAXIMUM PIPE SIZES:  
PLASTIC TWINWALL I/D: Ø 1500 mm  
CONCRETE I/D: Ø 1500 mm

**CUSTOM DESIGN**  
BESPOKE SOLUTIONS...

- CONCRETE
- STEELWORK
- HANDRAILS
- FLOW CONTROL

**INTEGRAL TOE**

**CAST-IN S/S SOCKETS**  
ACCURATE ALIGNMENT TO JOINT  
FITTINGS & OPTIONAL FEATURES

**OPTIONAL FEATURES**

**TOE BEAM RANGE**

- VARIOUS SIZE OPTIONS ARE AVAILABLE
- DOWEL PINS SUPPLIED TO SECURE TOE TO HEADWALL

**CONCRETE COLOURS**

- 24 COLOURS AVAILABLE IN RANGE FOR BLENDING ITEM WITH LOCAL ENVIRONMENT

**GRATINGS & TRASH SCREENS**

FACTORY FITTED AS STANDARD \*WHERE PRACTICAL / SAFE FOR TRANSPORT

- FULLY WELDED, HOT DIP GALVANISED STEEL & S/S FIXINGS AS STANDARD

- CLOSE COUPLED
- HINGED COUPLED
- SLOPED
- CRANKED

**KEE KLAMP HANDRAILS**

FACTORY FITTED AS STANDARD \*WHERE PRACTICAL / SAFE FOR TRANSPORT

- KEE KLAMP #8 AS STANDARD
- FULLY SIDED (CODE: K30)
- HALF WING (CODE: K50)
- BACK ONLY (CODE: K30)

**FLOW CONTROL DEVICES**

FACTORY FITTED (WHERE PRACTICAL / SAFE FOR TRANSPORT) AS STANDARD

- S/S FIXINGS & RUBBER SEALS / SEALANTS AS STANDARD

- FLAP VALVES
- PENSTOCKS
- ORIFICE PLATES
- BAFFLE BLOCKS

**ALUMINIUM STOPLOG SYSTEM**

CHANNELS FACTORY FITTED AS STANDARD \*WHERE PRACTICAL / SAFE FOR TRANSPORT

- VARIOUS BOARD HEIGHT / TYPES AVAILABLE
- LOCKING BRACKETS & T-KEY KITS SUPPLIED, S/S FIXINGS & RUBBER SEALS AS STANDARD